

2 PIPE FANCOIL

Model TCE-DFA - 350~1200 : Chilled/Hot Water With Auxillary Electric Heater With Fresh Air Inlet

Coil Options: - 4 Row Coil

1. Supply Air Double Deflection Grille, 3 Sides Optional
2. Optional Side, Front or Top Opening, Sizes: 14x4, 14x6, 14x8, 14x10, 14x12
3. Supply & Return Shut off Valve
4. Cooling / Heating Actuator
5. Water Coil
6. Fan Motor
7. Electrical Box
8. Swaged Riser Connection
9. Return Air Filter
10. Motor Access Panel
11. P-Trap
12. Drain Pan
13. Front Access panel With RA Grille
14. Fresh Air Inlet Collar 5" Diameter

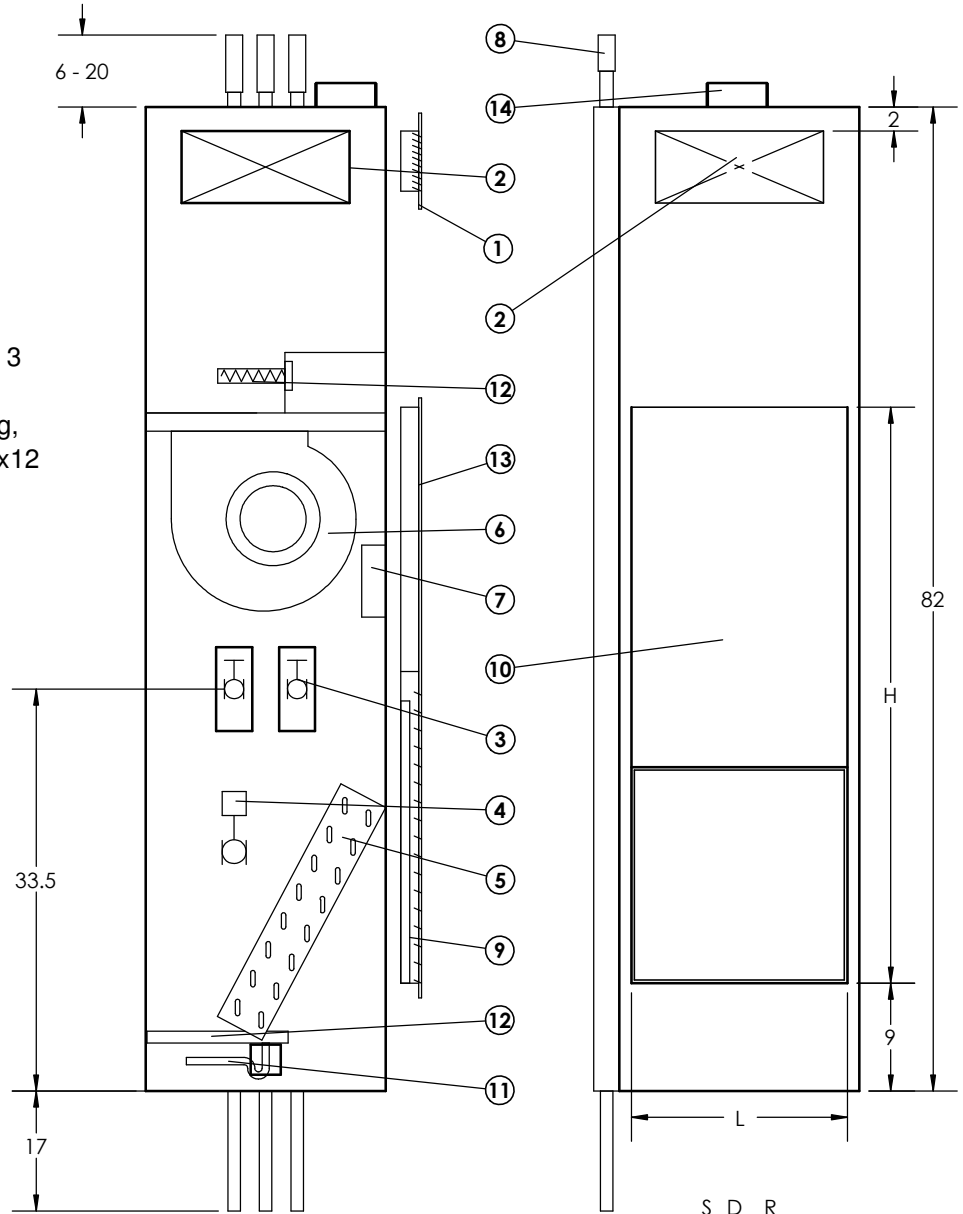

Performance Range

Air Volume

Fan Coil - 350 to 1200 CFM @ 0.5 ESP

Thermal Performance

Fan Coil - Nominal ¾ to 3 ton cooling

Nominal 15 MBH to 84 MBH heating

Dimensional Data					
Unit Size	A	B	L	H	Return Air Filter size
350	17.75"	19.75"	14"	48"	14"X20"X1"
450	17.75"	19.75"	14"	48"	14"X20"X1"
650	17.75"	19.75"	14"	48"	14"X20"X1"
800	20"	19.75"	16"	52"	16"X20"X1"
1000	20"	19.75"	16"	52"	16"X20"X1"
1200	20"	19.75"	16"	52"	16"X20"X1"

