

CLIMETEC

VERTICAL FAN COIL UNITS



VERTICAL FAN COIL UNITS

Model: CT & TCE 2 - Pipe

- 350 cfm to 1200 cfm capacity
- 4-row water coil
- 120v or 24v controls
- Electric heating coil (TCE Model)
- Fresh air connection from remote HRV (DFA option)
- ECM or PSC motor
- Unit mounted supply, return and drain risers
- 1" polyethylene or 1" fiberglass pipe insulation
- Quick access panel removal
- 1" disposable polyester filter
- Unit mounted aquastat for heating/cooling change-over
- 2 or 3 - way control valve assembly

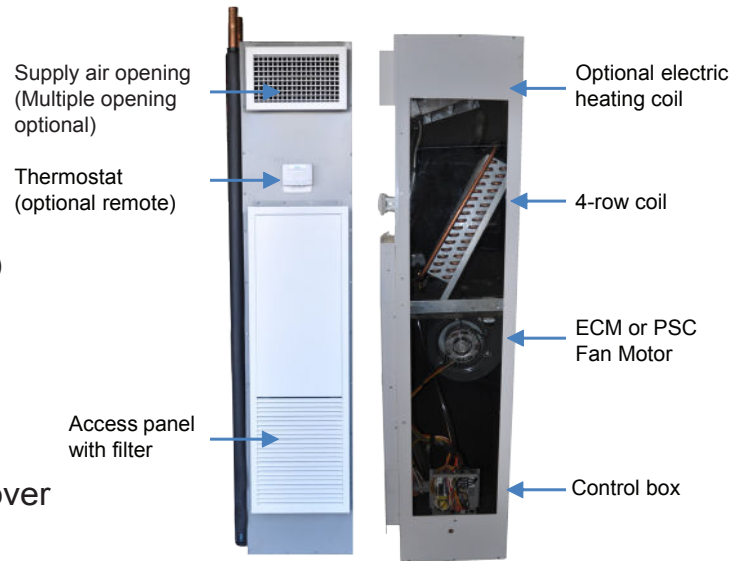

Model: TD 4 - Pipe

- 350 cfm to 1200 cfm capacity
- Split water coil
- 4-rows cooling
- 2-rows heating
- 120v or 24v controls
- Fresh air connection from remote HRV (DFA option)
- ECM or PSC motor
- Unit mounted supply, return and drain risers
- 1/2" polyethylene or 1" fiberglass pipe insulation
- Quick access panel removal
- 1" disposable polyester filter
- 2 or 3 - way control valve assembly

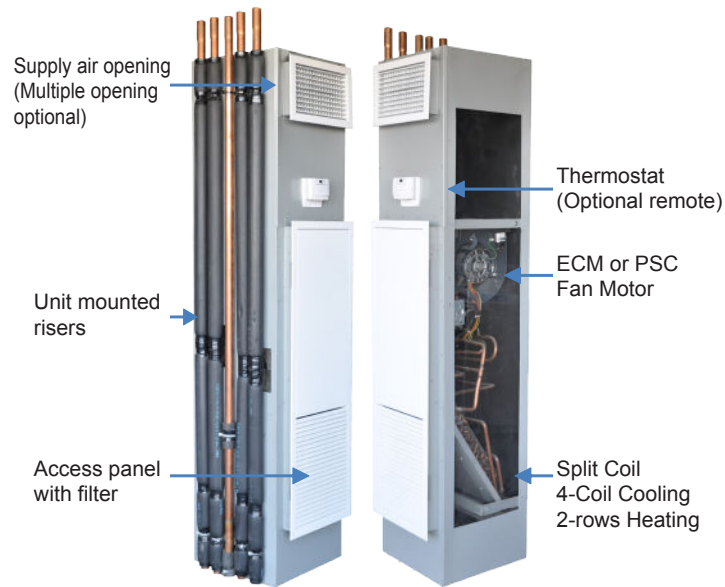

Model Series	350	450	650	800	1000	1200
Nominal Cooling (Ton)	0.75	1.0	1.5	2.0	2.5	3.0
Cooling Performance						
Cooling Capacity (BTUH)	8.2	12.9	20.6	24.9	31.6	35.8
Heating Performance						
Heating Capacity (BTUH)	19.4	27.6	38	46.2	70.2	81
Design Conditions						
Design CFM	350	450	650	800	1000	1200
Design Water Flow (GPM)	1.0	2.0	2.5	3.0	3.5	4.0
Water Coil Type 0.5 in. OD copper tubes, mechanically bonded aluminum fins						
Face Area (sq ft)	0.83	0.83	1.38	1.66	2.1	2.1
Rows/Fins Per Inch	3 Rows / 12 FPI	4 Rows / 12 FPI	4 Rows / 12 FPI	4 Rows / 12 FPI	4 Rows / 12 FPI	4 Rows / 12 FPI
Blower/Motor Forward curved, double inlet centrifugal / ECM direct drive						
Diameter x Width (in)	9 x 4	9 x 7	9 x 7	9 x 7	10 x 10	10 x 10
ECM Motor HP	1/4	1/3	1/3	1/3	1/3	1/3
Filters Disposable 1 in. polyester wire frame						
Size (in)	13.5 x 20	13.5 x 20	13.5 x 20	15.5 x 20	15.5 x 20	15.5 x 20
Cabinet 18 gauge galvanized / satin coat steel						
Cabinet Dimension (in)	17.75 x 18.25	17.75 x 18.25	17.75 x 18.25	20 x 18.25	20 x 18.25	20 x 18.25
Cabinet Weight (lb)	185	185	190	200	210	210

1) Cooling capacities are based on entering air conditions of 80 °F db / 67 °F wb, 44 °F entering water, high fan speed.
 2) Heating capacities are based on entering air conditions of 70 °F db, 160 °F entering water, high fan speed.

Manufacturing quality fan coil units for more than 25 years has been a founding principle of a company with humble beginnings. Climetec Industries Inc. commenced operation at a small facility in Toronto, Canada manufacturing vertical fan coil units for luxury condominiums and hotels.

Leading developers have chosen Climetec fan coils because “they are the quieter ones”. Today, our fan coil units are manufactured in a recently expanded 30,000 square foot facility strategically located in the Greater Toronto Area, servicing an ever expanding high rise market.

With a continually increasing demand for our products Climetec is committed to setting new standards in meeting the expectations of installers and ultimately those that use our products.

The Climetec vertical fan coil unit has been developed with input from engineers, contractors and end users and addresses the needs and concerns of all these groups.

The engineer wants guarantees of performance and expects the unit to meet capacity and noise specifications.

Climetec vertical fan coil units are capable of adapting to a wide variety of space requirements, installation configurations, and usage applications. The models feature designs that will blend in beautifully with any interior décor and boast advantages such as quiet operation, high energy efficiency, space-saving compactness, and easy installation and maintenance.

The contractor needs equipment that is easy to install and has full technical back-up of the manufacturer.

The end user expects the unit to be quiet and reliable with low maintenance costs and to provide a comfortable environment in all seasons.

By attention to design detailing and by careful assembly, Climetec has ensured that all of these requirements are met.



NEW INTEGRAL THERMAL RECOVERY FAN COIL UNITS

Model: CL-HRV & CLE-HRV 2 – Pipe
Model: CLS-HRV 4 - Pipe

- Improves indoor air quality (IAQ)
- Helps to meet stringent LEED and municipal energy savings
- Removable thermal recovery core
- Constant tempered air
- Ultra low noise levels

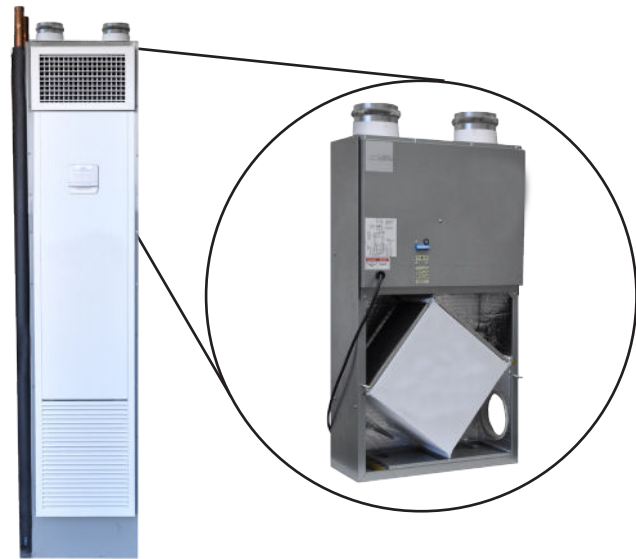

SPECIFICATIONS:

Case:

• 24 gauge galvanized steel. Size 19.5" x 35.5" x 9". HRV cabinet is fully insulated with 1" aluminum foil-face fiberglass to prevent condensation and meet the requirements of the UL and local building code.

Motor:

• Two fans, one fresh air intake, another for exhaust. Motors are factory balanced PSC motor with forward curved blades, permanently lubricated sealed ball bearings for long life and maintenance free operation.
 • Motors complete with 2-speeds, low speed between 35 cfm - 45 cfm, and high speed regulated to 75 cfm to avoid airflow variation due to pressure changes.

Timer Control:

• Installed in bathrooms by others, the time base is 20-40-60 minutes.

Speed Control:

• Automatically switches to high speed when defrost cycle is activated, installed by others;
 - Intermittent: 20 minutes low speed operation, 40 minutes f.
 - Low: Continuously on low speed, between 35-45 cf
 - High: Continuously on high speed 75 cf
 - f.

Core:

• Cross flow polypropylene core (HRV,ERV), size 12" x 12" x 7".

Filters:

• Two washable air filters with frame, exhaust side and intake side, size 12" x 7" x 3/8".

Defrost:

• A pre-set 6 minute defrost sequence is activated when outdoor air temperature is below 23 F (-5 C). During the defrost sequence, the intake air fan will shut down and allow exhaust air only to regenerate the core and maximize the effectiveness of the HRV ventilator. The unit then returns to normal operation for 20 minutes, and continues cycle; in extreme weather if the temperature is below -15F (-26 C) the HRV will run 10 minutes defrost and 20 minutes normal operation, then repeat the cycle.

Drain:

• Drain pan on the bottom complete with 2 piece 3/8" OD drain connection.

Duct Connection:

• 5" plastic duct connections with rubber gasket for easy sealing for designed airflow rate 75 cfm and below. 6" plastic duct connections with rubber gasket for designed airflow rate above 75 cfm. Air flow regulator will be installed in both to maintain constant cfm in high speed.

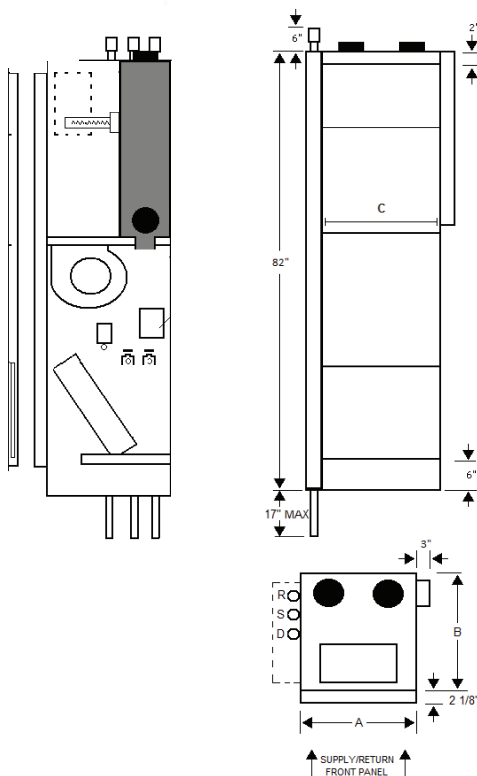

Unit Size	Dimensional Data			Filter size
	A	B	C	
350-1200	20"	20"	20"	19.5" x 20"

NEW ECM FAN TECHNOLOGY

Features

- Controller allows for fully variable speed retrofits
- Three selectable factory programmed speeds
- Programmable for Hi-Static applications
- Automatically compensates for increased static pressure while maintaining constant cfm
- Available with a constant ultra low fan speed when mated with a thermal recovery unit

Benefits

- More energy efficient solution over standard PSC motor
- Up to 56% savings of consumed electricity
- Efficiencies exceeding 80%
- Low voltage AC or DC thermostat inputs allow for use of existing system controls
- Longer motor life. Approx. 90,000 hrs vs. 50,000 hrs for PSC

Specifications

- Variable speed, constant cfm motor
- 120v AC single phase input, 1/4 hp or 1/3 hp
- Operation speed range: 300 - 1800 RPM
- UL and cUL recognized component

ENERGY CONSUMPTION ECM vs. PSC

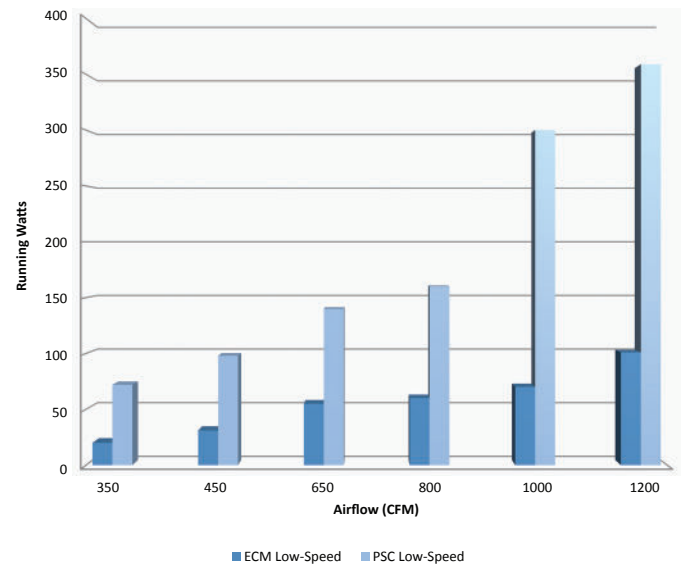

CONTROLS, PIPING AND ACCESSORIES



3-Way, 2-Position Control Valve / Actuator

- Three-way/two-way Cartridge Cage Valve
- Quick open
- Mixing or diverting application
- High close-off rating
- Maximum Safe Operating Pressure – 300 psi
- Ambient Temperature Range – 32 F to 160 F



Manual Ball Valve

- Allow the unit to be isolated for servicing
- Full port
- Compact handle that rotates 90 degrees
- Nominal size: 1/2" or 3/4"
- Pressure rating: 600 psi max.
- Temperature rating: 325 F max



Access Panel

- Engineered for a perfect fit onto the vertical fan coil unit
- Silent Operation - Ideal for luxury condos, hotels, hospitals and schools
- Removable door system provides easy access and one man operation
- Appliance white finish
- Available in custom sizes, with cylinder locks and other optional features to meet specifications



Electric Heater

- 0.75 to 1.5 kw in size
- High-limit cut out switch with auto reset
- Provides some heat during shoulder seasons



Thermostat

- TB6575 120v unit mounted
- TB8575 24v remote or unit mounted
- TB7100 24v 7 day Programmable
- Versa speed fan ramp automatically adjusts Low, Medium and High fan speed



Expansion Loop Assembly

- 1" to 3" sizes available
- Elbows cut back for maximum live length of 18.5"
- Working pressure above 200 psi
- Hose rated for: -40 F to 400 F

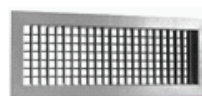

Grilles

- Steel fabricated with airfoil louvers
- Appliance white finish
- Double deflection with adjustable louvers
- Opposed blade dampers (optional)
- Friction fit
- Available in custom sizes

SPECIFICATIONS

STANDARD

Construction:

- Manufactured from 18 ga. galvanized or satin coat steel
- Casing with 1/2" thermal acoustical black mat coated fiberglass insulation.
- Casing height at 8".

Coils:

- Coils are 1/2"OD copper tubes with mechanically bonded aluminum fins.
- 12 fins per inch
- Manual air vents
- Coils are tested at 400 PSI from manufacture.
- 4 row chilled or hot water.

Return Air Access Panel:

- Manufactured in satin coat steel and finished with powder coated paint in a designer white.
- 20 ga. access panel with removable door.
- 14"x48" and 16"x48" panel sizes
- 1" disposable polyester filter.

Electrical:

- CS approved control arrangements.
- 120 volt (60 Hz) power supply.
- 24 volt controls with remote mounted thermostat
- 120 volt with unit mounted thermostat
- 15 amp disconnect switch

OPTIONS

Construction:

- Casing available with smaller footprint and height
- D A option includes fresh air inlet from remote HRV unit.

Drain Pans:

- Manufactured from 18 ga. stainless steel
- 7/8" drain connection
- Condensate overflow switch

Return Air Access Panel:

- Custom frame and door sizes
- Tamper proof screws.
- 2" high efficiency pleated filter.
- Custom colours

Electrical:

- CS Special Inspections for alternate control arrangements.
- 24 volt 7 day programmable thermostat
- 20 amp disconnect switch
- Provisions for energy metering device
- Electric heating coil: 0.75, 1.0 and 1.5 kW.

Fan Assemblies:

- Forward curve centrifugal fan with painted steel housing and galvanized steel wheel.
- Three speed PSC motor with built in thermal overload protection and torsion flex mounted.
- Easily removable fan / motor housing

Drain Pans:

- Manufactured from 18 ga. galvanized steel
- Corrosion resistant powder coat finish on the collection side of pan.
- 1/2" thermal acoustical black mat coated fiberglass liner below pan.
- 1/2" drain connection to riser.

Supply Air Grille:

- Steel fabricated with airfoil louvers and appliance white baked enamel finish.
- Double deflection with adjustable louver blades and friction fit.

Risers:

- Type L, M or DWV copper.
- 107" long risers
- 3" swaged end connections
- 3/4" to 3" pipe diameters
- Fully insulated and factory mounted

Fan Assemblies:

- Four speed PSC motor with constant ultra-low fan speed
- High efficiency three speed ECM motor.
- High efficiency four speed ECM motor with constant ultra-low fan speed.

Coils:

- 14 fins per inch
- Auto air vents.
- 3 row chilled water.
- 1 or 2 rows hot water.

Supply Air Grille:

- Sight and sound baffles.
- Opposed blade dampers
- Custom sizes
- Custom colours

Risers:

- Max 121" risers
- Riser extensions
- Riser package shipped separately from unit
- Factory mounted expansion loop assembly.